



Instructions for Moultrie Programmable Digital Timer Quick-Lock Kits

THANK YOU for your purchase of a Moultrie Quick-Lock Feeder. Please read this sheet before operating the unit. If you should have any questions about this product or any other Moultrie product, please contact us using the information on the back of this sheet. Allow us to better serve you by activating your 1-year warranty online at <http://www.moultriefeeders.com/warranty>

A CONFIGURING AND TESTING FEEDER

1 INSTALL BATTERY: Open Kit by removing wingnut located on the bottom and remove outer case. Install a 6-Volt Alkaline (ex. Energizer™) or Moultrie rechargeable battery (MFH-SRB6) by attaching the Red Alligator Clip to the positive terminal (+) and the Black Alligator Clip to the negative (-) terminal. **Note: When Battery Level Indicator is full, the battery is good. If the icon is flashing, you will need to replace or recharge your battery.**

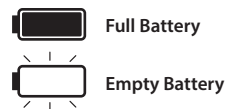

2 SET TIME OF DAY: Press the UP or DOWN button until the correct time of day appears. Press and release button to single-step through the minutes or hold down to advance quickly.

3 SET FEED TIMES: Press the SET button until the correct Timer Number appears in the upper right hand corner as shown. Press the UP or DOWN button to set the Feed Time. **Note: Factory settings are 7am and 6pm.**

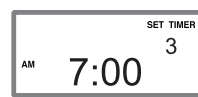

4 SET RUN DURATION: Press the SET button again to set the RUN-TIME SECONDS which can range from zero to twenty seconds. Adjust RUN-TIME SECONDS using the chart below. Set the RUN-TIME SECONDS to zero to disable the specific timer. **Note: Factory setting is 4 seconds.**



| RUN TIME (sec.) | 1 | 2 | 3 | 4 | 5 | 6 | 7 | 8 | 9 | 10 | 11 | 12 | 13 | 14 | 15 | 16 | 17 | 18 | 19 | 20 |
|-------------------------------|-----|-----|-----|-----|-----|-----|-----|-----|-----|-----|-----|-----|-----|-----|-----|-----|-----|-----|-----|-----|
| Approx. Feed Dispensed (lbs.) | .38 | .62 | .88 | 1.0 | 1.2 | 1.5 | 1.7 | 1.9 | 2.2 | 2.4 | 2.6 | 2.8 | 3.0 | 3.3 | 3.5 | 3.7 | 4.0 | 4.2 | 4.4 | 4.6 |

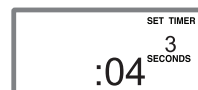

5 SET FEED LEVEL: Your Feeder Timer is equipped with a Feed Level Estimator. Press the SET button until "SET FEED REMAINING" appears. Enter the amount of feed (lbs.) added to Hopper. The timer will automatically estimate the amount of feed remaining in lbs. and days after auto-scroll begins.



Note: The above estimates are based on using deer corn. Feed type, size and density will affect calculations.



TEST FEEDER: PRESS AND HOLD the SET button while the RUN-TIME SECONDS are displayed. Release the button and get away from the feeder when the message "TESTING GET AWAY" appears on the display.



If mounting the Moultrie Quick Lock Feeder Kit to:

- a Moultrie 30 or 55-gallon barrel* or Moultrie 6.5-gallon bucket, refer to Section B.
- a Moultrie 30-Gallon Quick-Lock Hopper, refer to Section C.
- for any other containers, please visit our website at www.moultriefeeders.com

B ASSEMBLE WITH MOULTRIE QUICK-LOCK ADAPTER

55-Gallon or 30-Gallon Barrel*

- Assemble Quick-Lock Adapter by snapping Bolt Tabs in place as shown.
- Install Funnel inside of assembled Adapter with small end of funnel facing out, and attach with provided plastic push rivets or nuts and bolts.
- Turn the Metal Drum upside down and slide the Belly Band Ring around perimeter and make sure that belly band is snug against the bottom structure ring as shown (Moultrie barrel only).
- Slide the bolt through the Belly Band Ring, Spacer and Lock Washer as shown. Tighten nut on bolt until metal Belly Band Ring tabs are touching spacer on each side.
- Mount Quick-Lock Adapter using (3) 1/4" x 1" bolts, nuts and washers provided in the pre-drilled holes (Moultrie barrel only) or use the Quick-Lock Adapter as a template to mark and drill the mounting holes (non-Moultrie barrel).
- Connect Quick-Lock Feeder Kit to assembled Adapter as shown.

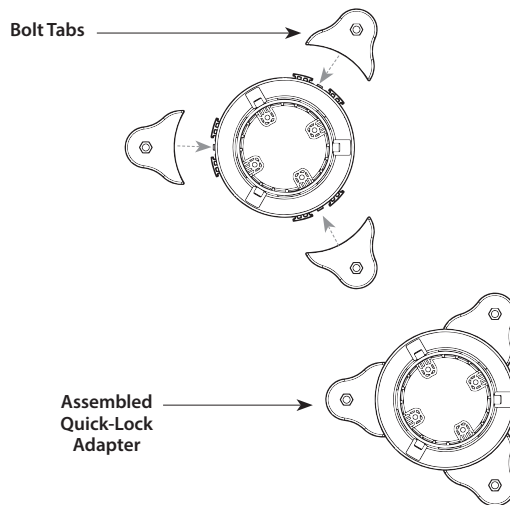

*Can also be used on a 6.5-Gallon Bucket.

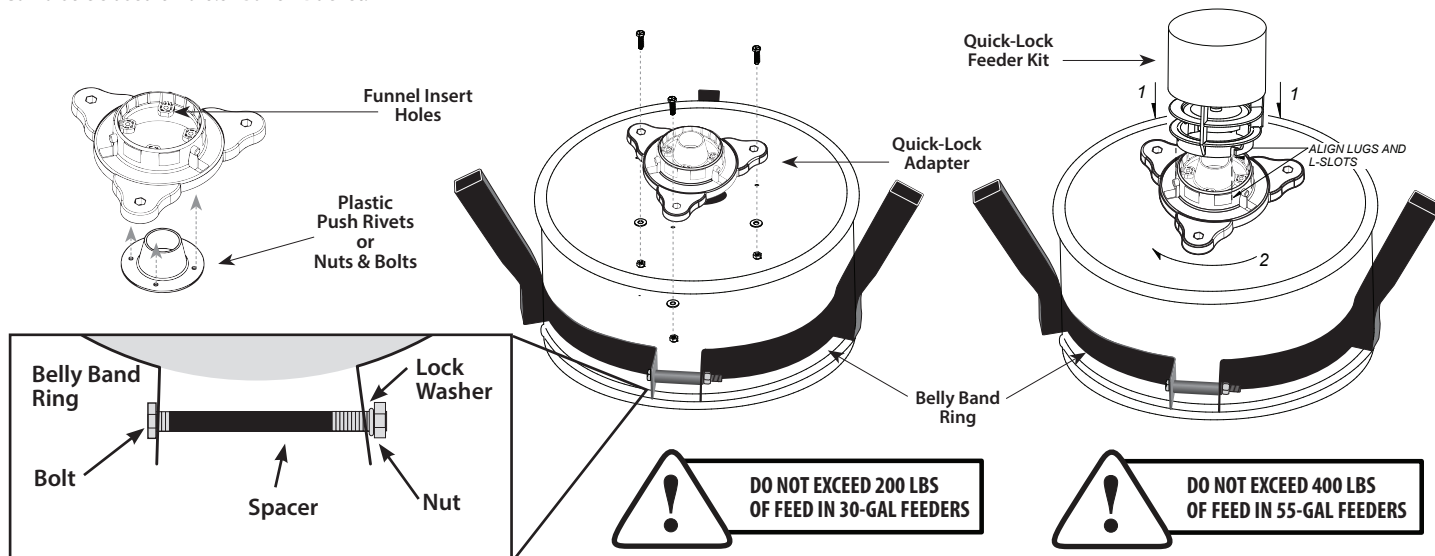

NOTE: DO NOT LOAD FEEDER until it is standing up and in place (see Section C-5).

C

ASSEMBLE WITH MOULTRIE QUICK-LOCK HOPPER

- 1** Place Funnel into Hopper Bottom and insert four (4) Plastic Push Rivets.

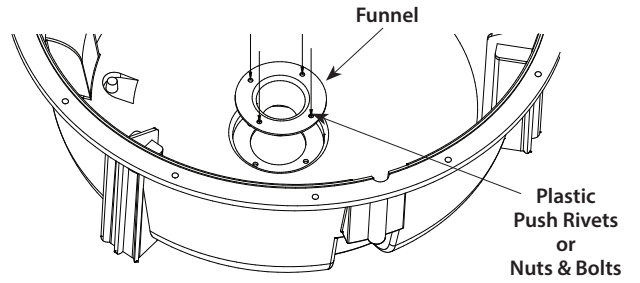

- 2** Flip Hopper Top upside-down and mate to Hopper Bottom.

Align holes, then press sides of Hopper Bottom until it snaps snugly in place. Insert Bolt upward through each hole, place Lock Washer on bolt and screw Wingnut onto bolt until tight. Repeat for all 12 bolts.

Note: Failure to properly secure 2 halves can result in leakage.

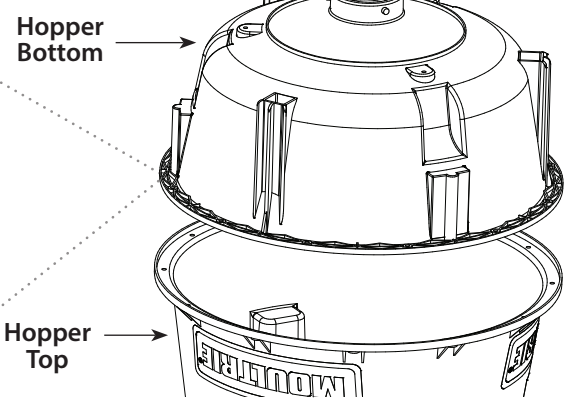
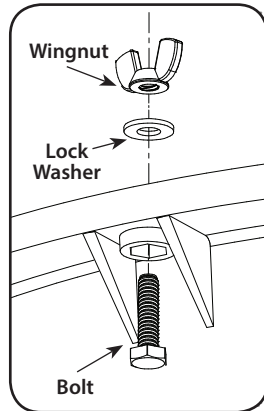

- 3** Connect Quick-Lock Feeder Kit to assembled Hopper as shown.

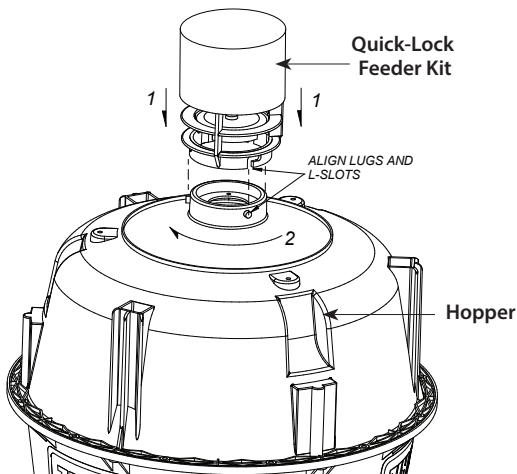

- 4** Slide the three provided Square Leg Brackets into the Hopper as shown.

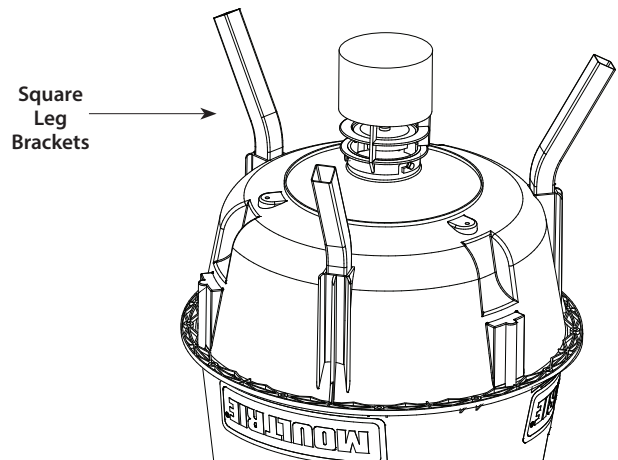

- 5** Stand Up Feeder and Install Lid

Place Hopper on side. Assemble three Leg Poles using two Leg Sections each for the Moultrie Deer Feeder Classic and Pro. For the Moultrie Deer Feeder Elite, you have three height options; assemble two Leg Sections (5' Fill Height), Three Leg Sections (7' Fill Height), or Four Leg Sections (8' Fill Height).

Install a Leg Pole on the inside of each of the Square Leg Brackets. Make sure to have all leg sections connected properly with the sections inserted as far as they will go. With two Leg Poles against the ground as shown, carefully stand up the Feeder assembly.

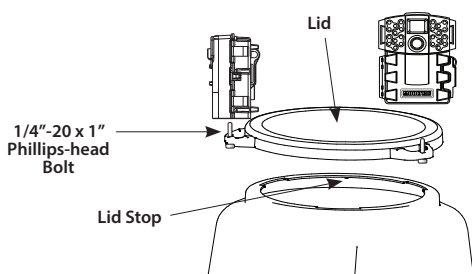
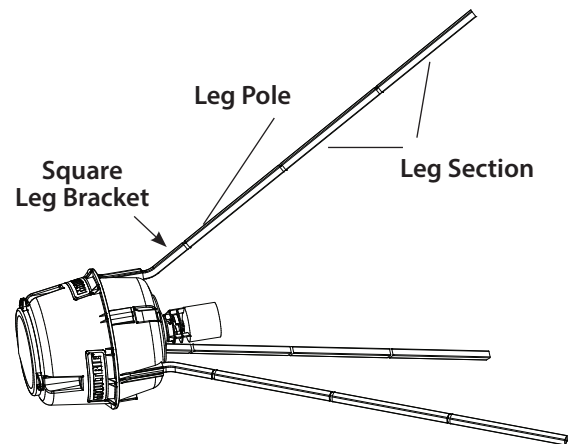

Install Lid by aligning handles with notches in Hopper Top. Twist until Lid rests flush against Lid Stop.

To install a Moultrie Game Camera or Feeder Power Panel (sold separately), thread included 1/4"-20 x 1" Phillips-head Bolt upward through hole in Lid Handle and tighten Bolt. Lid will hold up to 3 devices.



Our Service Department will gladly answer any questions you have.
Call 800-653-3334, Monday - Friday, 8:00 AM to 5:00 PM CST.
www.moultriefeders.com